

Technical Specification Energy 2015 – Harmonized Design of Overhead Contact Lines

Thomas NICKEL¹, Rainer PUSCHMANN²

Summary

The Technical Specification for Interoperability of the Energy subsystem of the railway systems in the European Union was published in December 2014. This Technical Specification came into force on January 1, 2015 and replaced the individual Technical Specifications for the interoperability of conventional and high-speed railway systems in force to date. The document stipulates detailed rules for the design of the mechanical-kinematic gauge of the pantograph and the maximum lateral deviation of contact wires. The harmonized stipulations result in planning data for contact lines which differ from design values obtained previously. Furthermore the article identifies necessary supplements for the next Technical Specification for Interoperability of Energy subsystem.

Keywords: overhead contact line, interoperability, technical specification of interoperability, energy subsystem, conventional railway, high-speed railway, mechanical kinematic gauge of pantograph, electrical kinematic gauge of pantograph, supplements of Technical Specification for Interoperability of Energy subsystem

1. Introduction

On December 12th 2014 the European Union published the Technical Specification for the Interoperability of the Energy Subsystem (TSI ENE) [22] in their Official Journal. The publication as a *Regulation* does not require implementation into national law. The TSI applies directly and has been in force since January 1st, 2015 [9]. The new TSI ENE combines the previous separate specifications for high-speed rail systems [2] and for conventional rail systems [3]. The TSI ENE encompasses planning, installation and operation of overhead contact line systems within the Trans-European Network (TEN) of the European Union. The origin of the TSI ENE and their essential contents has been described in [16].

The European Railway Agency (ERA) commissioned an investigation into the provision of stable and reliable information on system design within the member states because it realized that differing system design tools used by European infrastructure managers pose a barrier between the countries of Europe.

The space to be kept free for the passage of the pantograph and the usable contact wire lateral position on the pantograph form essential interfaces between the subsystems *Energy* and *Rolling Stock* [23] (Figure 1). The calculations of the interfaces are based on the specifica-

tions of the mechanical-kinematic pantograph gauge also called pantograph limit gauge. For this purpose, the new TSI ENE [22] contains detailed instructions for calculation, which shall be used by all infrastructure managers in Europe and, therefore, harmonizes the national calculation rules used to date. The verification, of the mechanical-kinematic pantograph gauge is met forms a part of the EU certification of the subsystem *Energy* for overhead contact lines as an interoperability constituent.



Fig. 1. ICE 3 and overhead contact line type Sicat H on the high-speed line Cologne – Frankfurt [Photo and Figures SPL Powerlines Germany]

¹ Dipl. Ing.; SPL Powerlines Germany.

² Dipl. Ing.; Expert Consultancy Germany; e-mail: rainer.puschmann@expert-consultancy.com.

2. Pantograph gauge

2.1. General

The pantograph gauge determines the space to be kept free for the unhindered passage of pantographs. Except for the contact wire, the steady arms and the wind stay, no other components are permitted within the pantograph gauge. On each line on which different pantograph profiles are used the longest pantograph head determines the pantograph gauge.

The establishment of the pantograph gauge is based on the calculation procedures for the structure gauge, however also includes some specialities. In operational condition the pantograph contacts the contact wire continuously and therefore, the pantograph height varies. Accordingly, the height and consequently the width of the pantograph gauge vary as well.

The structure gauge is determined according to standard EN 15273 part 1 [11], part 2 [12] and part 3 [13]. The first part of EN 15273 [7] deals with general aspects which affect the infrastructure and the rolling stock, then the reference gauges and the corresponding standards. The second part [12] contains rules for the calculation of the vehicle gauge, depending on the rolling stock characteristics, on the chosen structure gauge and the related calculation instructions. The third part [13] contains calculation instructions for the structure limitation lines, also called structure gauges, which are necessary for the operation of railway rolling stock.

The standard distinguishes between the responsibility of the *infrastructure* and *rolling stock* subsystems. The reference gauge B as an interface separates the responsibility of the infrastructure and rolling stock structures (Figure 2). The infrastructure manager guarantees the open passage for the rolling stock with pantographs within the pantograph gauge while the rolling stock manager ensures that the operating rolling stock stays within the individual rolling stock gauges. Outside the reference gauge, the structure gauge C is defined based on the calculation rules according to EN 15273-1 [11]. The rolling stock gauge A is obtained using the calculation rules in EN 15273-2 [12] and starting from the reference gauge B (Figure 2).

The individual reference gauge, the rolling stock gauge and the structure gauge differ according to the calculation method used. EN 15273-3 distinguishes between the static, kinematic and dynamic calculation methods.

For determining the pantograph gauge the TSI ENE [22] uses the kinematic calculation method, which leads to the *mechanical-kinematic pantograph gauge*. The electrical minimum clearances are not taken into account when applying the calculation method according to EN 15273-3 [13] and have to be considered in addition by the infrastructure manager. Within the area of the pantograph, the *electrical*

kinematic pantograph gauge is created by adding the individual electrical clearances to the mechanical-kinematic pantograph gauge, which corresponds to the pantograph structure gauge.

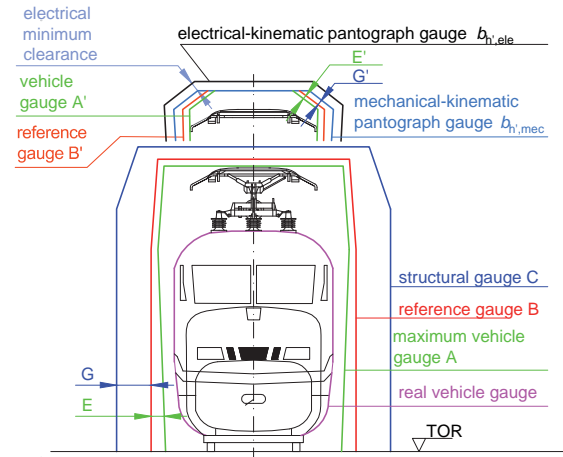

Fig. 2. Rolling stock gauge, reference gauge and infrastructure gauge

2.2. Calculation method

2.2.1. Mechanical-kinematic pantograph gauge

The width of the mechanical-kinematic pantograph gauge at the lower and upper verification points, respectively, results from [22]

$$b'_{u(i/a),mec} = (b_w + e_{pu} + S'_{i/a} + qs'_{i/a} + \sum j_u)_{\max} \quad (1)$$

and

$$b'_{o(i/a),mec} = (b_w + e_p + S'_{i/a} + qs'_{i/a} + \sum j_o)_{\max}, \quad (2)$$

where

b_w – half length of the pantograph head,

e_{pu} – pantograph sway at the lower verification point,

e_{po} – pantograph sway at the upper verification point,

$S'_{i/a}$ – additional overthrow on the inside/outside of the curve,

$qs'_{i/a}$ – quasi-static displacement (inside curve/outside curve),

$\sum j_u$ – sum of additional margins covering random phenomena at the lower verification point.

$\sum j_o$ – sum of additional margins covering random phenomena at the upper verification point.

According to EN 15273-3 the half length of the pantograph head and the sway of the pantograph are a property of the rolling stock deviation designated E' of the gauge A, while the additional projection, the deviation due to quasi-static inclination as well as the randomly related lateral deviation is added as a devia-

tion G' to the infrastructure part of the gauge C (Figure 2). The gauge B' , designated as reference gauge in TSI ENE, results from the sum of the half length of the pantograph head and its sway [22]. For verification at an optional variable height h' the width of the gauge is determined by interpolation

$$b'_{h,mec} = b'_{u,mec} + \frac{(h - h'_u)(b'_{o,mec} - b'_{u,mec})}{(h'_o - h'_u)}, \quad (3)$$

where

- h – verification height,
- h'_u – height of the lower verification point,
- h'_o – height of the upper verification point,
- $b'_{u,mec}$ – half width of the mechanical-kinematic pantograph gauge at the lower verification point,
- $b'_{o,mec}$ – half width of the mechanical-kinematic pantograph gauge at the upper verification point.

2.2.2. Verification height

According to TSI ENE [22] the height at the lower verification point is 5,0 m and the height of the upper verification point is 6,5 m above top of rail. The real verification height h is composed of

$$h = h_{FD} + f_s + f_{ws} + f_{wa}, \quad (4)$$

where

- h_{FD} – nominal contact wire height,
- f_s – lift of the contact wire due to passing pantograph,
- f_{ws} – inclination of the pantograph head,
- f_{wa} – wear of the pantograph contact strips.

The locally measured contact wire height should be used as the nominal contact wire height. If no data are available the planned nominal contact wire height including the vertical installation tolerance may be used. As an example, this is at maximum 100 mm [7] for the standard contact line type Re200.

The lift of the contact wire at trespassing of a pantograph has to be determined by measurements or simulation. The lift at supports depends on the overhead line design. For the standard Re200 design, the simulated maximum lift at the support is approximately 100 mm [10]. In addition, the contact wire will be uplifted around 100 mm [10] in the middle of the span.

The inclination of the pantograph head at an eccentric contact wire position and the wear of the contact strip together may not exceed 60 mm according to EN 50367:2012 [15] (Figure 3). The manufacturer of the pantograph and the rolling stock manager are responsible for meeting this requirement. For the standard contact line Re200 design with 5,50 m standard contact wire height [20] the verification height, is

therefore, 5,76 m at support and 5,86 m in the middle of the span.

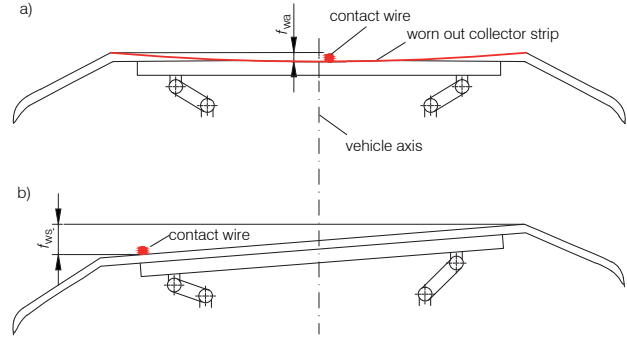

Fig. 3. Wear of the collector strip and skew of the pantograph head: a) worn contact strip, b) skew of the pantograph head

2.2.3. Length of the pantograph head

The length of the pantograph head depends on the type of pantograph used. In the TSI Rolling Stock [23] three types of pantographs are defined having the lengths 1 600 mm, 1 950 mm and 2 000/2 260 mm as interoperable pantograph heads. On standard gauge lines contact lines have to be designed for 1 600 mm and/or 1 950 mm long pantographs.

2.2.4. Pantograph Sway

The sway of pantographs (Figure 4) also called eccentricity of the pantographs [11] or lateral deviation of the pantographs due to rolling stock characteristics [26] represents the rolling stock related limiting position of the pantograph. For the rolling stock, it needs to be theoretically verified, that the movement of the pantograph will not be higher than the total permitted assumed values and that all mechanical parts of the pantograph stay within the reference gauge [11].

The sway of the pantograph follows from

$$e_p = sp + z' + \vartheta, \quad (5)$$

where

- sp – transverse play between wheelset and body of the vehicle,
- z' – displacement due to quasi-static inclination to be considered on the vehicle side,
- v – displacement due to transverse swing, position tolerance and asymmetry of the pantograph.

The transverse play for the reference vehicle is defined in EN 15273-1:2013 [11] as an all-inclusive value

$$sp = q_r + w_r = 0,0375 \text{ m}, \quad (6)$$

where

- q_r – transverse play between wheelset and bogie frame of the reference vehicle,

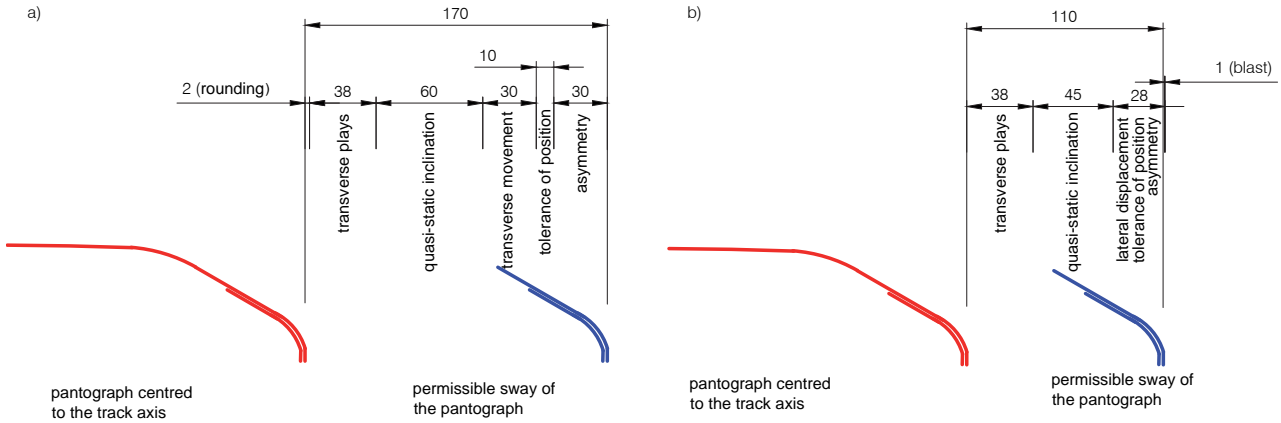

Fig. 4. Parameters affecting the pantograph in case of swaying; dimensions in mm, a) upper verification point, b) lower verification point

w_r – cradle transverse play between bogie and body of the reference vehicle.

The lateral displacement due to quasi-static inclination of the vehicle results from EN 15273-1:2013 for the outside of curve

$$z'_a = \frac{S'_0}{L} \cdot I'_0 \cdot (h - h'_{c0}), \quad (7)$$

and for the inside of curve

$$z'_i = \frac{S'_0}{L} \cdot D'_0 \cdot (h - h'_{c0}), \quad (8)$$

where

- S'_0 – flexibility for the pantograph gauge,
- L – distance between the central axes of the rails of a track,
- I'_0 – reference cant deficiency,
- D'_0 – reference cant,
- h'_{c0} – rolling centre height above the top of rail.

Reference cant and reference cant deficiency are 0,066 m each, whereby the same values for the quasi-static inclination of the vehicle follow from (7) and (8), inside and outside the curve. The displacement to be considered on the vehicle due to quasi-static inclination results, therefore, at the lower verification point to 0,045 m and at the upper verification point to 0,060 m.

The displacement due to transverse swing, tolerance of position and asymmetry of the vehicle is, according to EN 15273-1:2013 [11], taken as the geometrical sum at the lower verification point:

$$g_u = \sqrt{\left(t_r \cdot \frac{h'_u - h'_c}{h'_0 - h'_c} \right)^2 + \tau^2 + [\theta(h'_u - h'_{c0})]^2} = 0,028 \text{ m}, \quad (9)$$

whereas at the upper verification point the displacement is taken from UIC 505-5 [27]

$$g_0 = t_r + \tau_r + \theta_r \cdot (h_0 - h'_{c0}) = 0,070 \text{ m}, \quad (10)$$

where

- t_r – lateral displacement of the pantograph under a load of 300 N,
- τ_r – manufacture and installation tolerance of the pantograph,
- θ_r – asymmetry due to the suspension adjustment of the vehicle,
- h_t – installation height of the lower pantograph joint above top of rail,
- h'_{c0} – height of the rolling centre of the vehicle above top of rail.

The data for the parameters of the reference vehicle used for the calculation are summarized in Table 1. The sway of the reference pantograph (Figure 4) is at the lower verification point

$$e_{pu} = 0,038 + 0,045 + 0,028 = 0,111 \text{ m}, \quad (11)$$

and at the upper verification point

$$e_{p0} = 0,038 + 0,060 + 0,070 = 0,168 \text{ m}. \quad (12)$$

After rounding, these values coincide with the reference parameters given in TSI ENE [22]. However, the calculation of the sway of the pantograph according to UIC 505-5 [27] does not comply completely with the calculation methods according to EN 15273-1:2013 [11] since according to EN 15273-1:2013 a probabilistic mathematical approach is used for the effects of transverse swing, position tolerance and vehicle asymmetry, also for upper verification point. Therefore, EN 15273-3 uses also

at the upper verification point the geometrical sum according to equation (9) for the displacement due to transverse swing, position tolerance and asymmetry of the vehicle.

Table 1

Reference parameters

Parameter	Value	Source
D_o	0,050 m	UIC 505-5 [27]
D'_o	0,066 m	TSI ENE [22], 4.2.10
e_{po}	0,170 m	TSI ENE [22], 4.2.10
e_{pu}	0,110 m	TSI ENE [22], 4.2.10
h'_{co}	0,500 m	TSI ENE [22], 4.2.10
h'_o	6,500 m	TSI ENE [22], 4.2.10
h_t	4,005 m	UIC 505-1 [25], A.1.2
h'_u	5,000 m	TSI ENE [22], 4.2.10
I_o	0,050 m	UIC 505-5 [27]
I'_o	0,066 m	TSI ENE [22], 4.2.10
l	1,470 m	EBO, §5 [6]
L	1,500 m	EN 15273-3 [13], Table G.1
$q_r + w_r$	0,0375 m	EN 15273-3 [13], Table G.1
s_o	0,400	UIC 505-5 [27]
s'_o	0,225	TSI ENE [22], 4.2.10
t_r	0,030 m	EN 15273-3 [13], Table G.1
θ_r	0,005 rad	EN 15273-3 [13], Table G.1
τ_r	0,010 m	EN 15273-3 [13], Table G.1

2.2.5. Additional overthrow

The additional overthrow results from the position of the vehicle on a curved track (Figure 5) and on the track due to locally existing extensions of the track gauge because of tolerances and occurrence of wear (Figure 6).

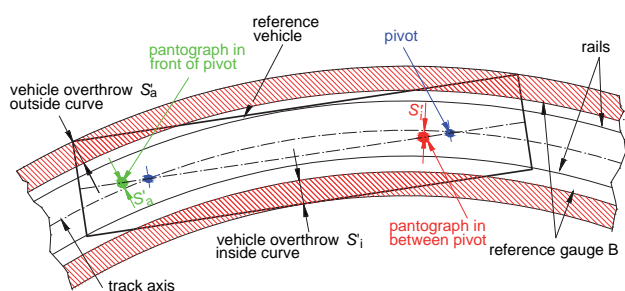

Fig. 5. Position of the vehicle in a curve. Stellung eines Fahrzeugs im Gleisbogen

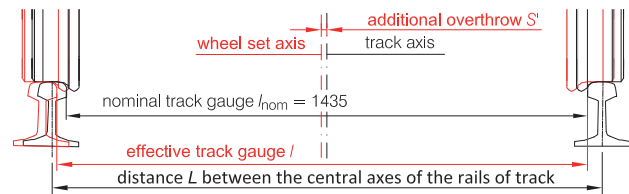

Fig. 6. Position of the wheel axis in a track with extended track gauge; dimensions in mm

The additional swing is

$$S'_{i/a} = \frac{2,5}{R} + \frac{l - 1,435}{2}, \quad (13)$$

where

R – horizontal curve radius,

l – track gauge, the tolerances and wear agreed upon included.

The permissible maximum values for the track gauge depend on the maintenance rules of the infrastructure manager and are not standardized within Europe. In Germany, the track gauge, according to the railway installation and operation regulation (EBO) [6] may not exceed 1 465 mm at main tracks and 1 470 mm at secondary tracks.

2.2.6. Quasi-static effect

The quasi-static effect results from the swaying movements of the vehicle under the action of the lateral acceleration on the sprung masses due to the gravitation or to the centrifugal force not compensated by the cant (Figure 7). This effect is taken into consideration by the infrastructure manager [11] as a function of the cant and the cant deficiency if the values are higher than the reference cant or the reference cant deficiency, respectively.

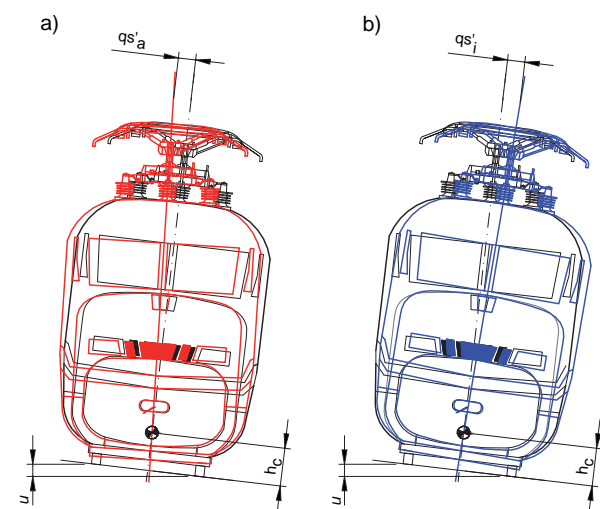

Fig. 7. Displacement due to quasi-static inclination: a) vehicle inclination outside curve during running in a curve with a cant deficiency, b) vehicle inclination inside curve at stand-still in a canted track

The displacements due to quasi-static effects result from

$$qs'_i = \frac{s'_0}{L} (D - D'_0)_{>0} (h - h'_{c0}), \quad (14)$$

and

$$qs'_a = \frac{s'_0}{L} (l - l'_0)_{>0} (h - h'_{c0}), \quad (15)$$

where

- S'_0 – flexibility taken into account for the pantograph gauge,
- L – distance between rail centres of the track,
- D – cant of the track,
- D'_0 – reference cant,
- I'_0 – cant deficiency of the track,
- I'_0 – reference cant deficiency
- h'_{c0} – rolling centre height above top of rail.

2.2.7. Sum of the random-related displacements

Calculation method

The sum of the random-related displacements takes into account the effects resulting from the randomly occurring phenomena [13]:

- Transverse displacement of the track between two consecutive track maintenance procedures,
- Transverse height defects of the track between two consecutive track maintenance procedures,
- Vehicle vibrations due to irregular track positions,
- Asymmetry due to installation tolerances of the vehicle suspension and non-uniform distribution of the load.

Due to the low probability of the coincidence of the maximum tolerances the sum of the random-related lateral displacements is calculated with the geometric average and a coefficient [13]:

$$\sum j = k \cdot \sqrt{\Delta b_1^2 + \Delta b_2^2 + \Delta b_3^2 + \Delta b_4^2 + \Delta b_5^2}, \quad (16)$$

where

- k – coefficient,
- Δb_1 – lateral displacement of the track,
- Δb_2 – displacement due to a transverse height deficiency of the track,
- Δb_3 – displacement due to vehicle vibrations because of irregularities of the track position,
- Δb_4 – displacement due to asymmetry of installation tolerances of the vehicle suspension,
- Δb_5 – displacement due to asymmetric distribution of the load on the vehicle.

Coefficient

The coefficient takes care of the low probability of a simultaneous occurrence of the limit values of oscillations and asymmetries. Due to EN 15273-1:2013 [11] it is not probable, that the sum of the limit values considered within the calculation will be exceeded by 20%. The violation of the pantograph gauge is considered as less important than the violation of the vehicle gauge, the coefficient is taken as $k = 1,2$ for the calculation of the sum of random-related displacements of the vehicle and as $k = 1,0$ for the displacement of the pantograph [13].

Transverse displacement of the track

The track position may change in between two inspections due to the effects of the train operation. The maximum transverse displacement depends on the maintenance conditions

$$\Delta b_1 = T_{\text{voie}}, \quad (17)$$

where

T_{voie} – transverse displacement of the track.

These effects may be neglected if the permanent way does not allow displacements towards structural systems as is the case of non-ballasted permanent ways [11].

Transverse height deficiency of the track

The transverse height of the track may deviate from the planned value due to maintenance tolerances and the operational load of the trains. The transverse height deficiency results on one hand in a geometric effect, that is the reference line to the track rotates with a certain angle relatively to the track axis and, on the other hand, in a quasi-static effect due to the elasticity of the suspension. All together the displacement will be

$$\Delta b_2 = \frac{T_D}{L} \cdot h + \frac{s'_0}{L} \cdot T_D \cdot (h - h'_{c0}), \quad (18)$$

where

T_D – transverse height defect of the track.

Vehicle vibrations generated by track unevenness

Vehicle vibrations are generated by unevenness of the track position mainly in case of ballasted permanent way. Their amplitude depends on the track quality, the suspension characteristics and the speed of the vehicle. As far as these effects need to be considered at structurally, the vibrations are expressed by corresponding cant deficiencies

Table 2

Sum of the randomly-related displacements according to EN 15273-3:2013 [13]

Parameter	Unit	Ballasted track				Unballasted track
		Very good track quality		Other tracks		
	km/h	v ≤ 80	v > 80	v ≤ 80	v > 80	
T_{voie}	m	0,025	0,025	0,025	0,025	0,005
T_{D}	m	0,020	0,015	0,020	0,015	0,005
T_{osc}	m	0,039 m	0,039	0,065	0,065	0,039
T_{charge}	degree	0,77°	0,77	0,77°	0,77	0,77
T_{susp}	degree	0,23°	0,23	0,23°	0,23	0,23
k	–	1	1	1	1	1
Σj_{u}	m	0,108	0,094	0,114	0,101	0,071
Σj_{o}	m	0,141	0,123	0,149	0,132	0,095

$$\Delta b_3 = \frac{s'_0}{L} \cdot T_{\text{osc}} \cdot (h - h'_{c0}), \quad (19)$$

where

T_{osc} – theoretical transverse height deficiency of the track as a basis to calculate the displacements due to vibrations generated by track position irregularities.

Asymmetry

The vehicle is not symmetric to the track axis due to adjustment tolerances of the suspension and non-uniform load distribution but displaced. The displacements resulting thereof are

$$\Delta b_4 = \tan(T_{\text{susp}}) \cdot (h - h'_{c0}), \quad (20)$$

and

$$\Delta b_5 = \tan(T_{\text{charge}}) \cdot (h - h'_{c0}), \quad (21)$$

where

T_{susp} – asymmetric angle due to not precise adjustment of the suspension,

T_{charge} – asymmetric angle because of unfavourable load distribution.

Data

Since the sum of the random-related displacements depends on the maintenance conditions of the infrastructure manager, uniform values do not exist for this data in Europe. EN 15273-3:2013 [13] contains recommendations for the coefficients to determine the allowances for the calculation of the mechanical-kinematic reference gauge. In this case, it is distinguished between ballasted tracks and unballasted tracks as

well as between two areas of speed and track quality. The values and random-related displacements resulting thereof at the lower and upper verification height are summarized in Table 2. In Germany, EBO [6] describes values for the sum of the random-related displacements. These data are given in Table 3.

Table 3

Randomly related displacement according to EBO [6], all dimensions in m

Parameter	Not fixed track	Fixed track	Fixed track and cant or transverse height deficiency ≤ 5 mm
Σj_{u}	0,079	0,073	0,025
Σj_{o}	0,099	0,095	0,032

A comparison of the data based on the recommended coefficients according to EN 50273-3 [13] and the values according to EBO reveals that according to EN 50273-3 values at least higher by a factor of 1,2 are stipulated. EBO does not give reasons for the values, however, they can be confirmed empirically: For the operational tolerances of the permanent way other values apply for the German railway system according to the DB Network Directive 821 [4] than those recommended by EN 15273-3 [13].

In the DB Network Directive 821 [4] it is stipulated that differences within ±15 mm between the actual cant and the planned value are acceptable for all types of tracks and speeds. According to EBO, the consideration of vehicle vibrations caused by track unevenness is based on an excellent track quality. According to this regulation a cant deficiency of 39 mm needs to be assumed in order to model the effects of track unevenness.

Additionally, the sum of the asymmetry angles of the vehicle due to manufacturing tolerances, suspension adjustment and non-uniform vehicle loading is not considered by the reference value 1, since vehicles with pantographs are equipped with a stiffer suspension. The flexibility will be 0,225 for vehicles with pantographs on the roof. Therefore, the angles to determine the asymmetry are

$$T'_{susp} = T_{susp} \cdot \frac{s'_0}{s_0} = 0,23^\circ \cdot \frac{0,225}{0,400} \approx 0,13^\circ \quad (22)$$

and

$$T'_{charge} = T_{charge} \cdot \frac{s'_0}{s_0} = 0,77^\circ \cdot \frac{0,225}{0,400} \approx 0,43^\circ \quad (23)$$

This procedure coincides with the stipulations according to DIN EN 15273-1:2013 [11]: *Since a stiffer vehicle is assumed the maximum value of neither T'_{osc} nor of T'_{charge} and nor of T'_{susp} need to be considered for the reference vehicle having s_0 , but the interpolated values proportional to s/s_0 are since a less stiff vehicle will vibrate more severely and will be inclined more than a more stiff vehicle.*

Under consideration of the mentioned coefficients the randomly caused displacements for a non rigid track at the lower verification point are

$$\Delta b_1 = 0,25 \text{ m},$$

$$\Delta b_2 = \frac{0,015}{1,500} \cdot 5,0 + \frac{0,225}{1,500} \cdot 0,015 \text{ m} \cdot (5,0 \text{ m} - 0,5 \text{ m}) = 0,060 \text{ m},$$

$$\Delta b_3 = \frac{0,225}{1,500 \text{ m}} \cdot 0,039 \text{ m} \cdot (5,0 \text{ m} - 0,5 \text{ m}) = 0,026 \text{ m},$$

$$\Delta b_4 = \tan(0,13^\circ) \cdot (5,0 - 0,5) = 0,010 \text{ m},$$

$$\Delta b_5 = \tan(0,43^\circ) \cdot (5,0 \text{ m} - 0,5 \text{ m}) = 0,034,$$

$$\sum j_u = 1,0 \cdot \sqrt{\frac{(0,025)^2 + (0,060)^2 + (0,026)^2}{+(0,010)^2 + (0,034)^2}} = 0,079 \text{ m},$$

and summarized at the upper verification point

$$\sum j_0 = 1,0 \cdot \sqrt{\frac{(0,025)^2 + (0,079)^2 + (0,035)^2}{+(0,014)^2 + (0,045)^2}} = 0,101 \text{ m}.$$

The data for the randomly-caused lateral displacements according to EBO [6] apply to speeds up to 160 km/h. The values according to EN 15273-3:2013 [13] can be used without any limitation caused by the speed.

2.2.8. Pantograph gauge

Using the impacts described in the sections 2.2.1 to 2.2.7 for the determination of the mechanical-kinematic pantograph gauge and assuming that the cant is always greater than the cant deficiency the quasi-static displacements will be

$$qs'_i = s'_0 (D - D'_0)_{>0} (h - h'_{c0}) / L = 1,5 (D - 0,066)_{>0} (h - 0,5), \quad (24)$$

and the mechanical-kinematic pantograph gauge results from

$$b'_{h,mec} = b_w + \frac{2,5}{R} + \frac{l - 1,435}{2} + 1,5 (D - 0,066)_{>0} (h - 0,5) + \left\{ (0,11 + \sum j_u) + \frac{h - 5,0}{1,5} [(0,17 + \sum j_0) - (0,11 + \sum j_u)] \right\}. \quad (25)$$

2.3. Standard gauge

The standard gauge is the gauge to be used for the infrastructure having a constant cross section and is designed for the most unfavourable case. The limiting lines of the standard gauge profile GC according to EN 15273-3:2013 [13] and according to EBO [6] have been calculated for track radii of ≥ 250 m and a cant ≤ 160 mm.

The widths of the standard gauge for electrified lines according to EBO are given in Table 4 depending on the working height of the pantograph. In this case, it has to be observed that the electrical minimum clearances for 15 kV have already been considered.

Table 4
Dimensions of the standard gauge of overhead contact lines according to EBO [6], all dimensions in m

Working height of the pantograph	$h \leq 5,3$	$5,3 < h \leq 5,5$	$5,5 < h \leq 5,9$	$5,9 < h \leq 6,5$
b_{EBO}	1,430	1,440	1,470	1,510

The standard gauge has to be kept free of hindrances for an unhindered passing of the pantograph. At constraints the pantograph gauge can be determined for the individual case if some components such as the

hook end fitting of the steady arm, the drop bracket or a displaced insulator approach the standard gauge. A violation of the pantograph gauge by infrastructure components is not permitted.

2.4. Bevel of corners

The geometry of the pantograph with the contact horns is accommodated by the pantograph gauge by bevelling of the corners. The bevelling starts in each case at the outer limit line at the verification height in direction of the pantograph axis and from this reference point downwards.

Figure 8 shows the bevells for the pantograph lengths 1 600 mm and 1 950 mm. The dimensions in blue are valid for the 1 600 mm long pantograph and defined in EN 15273-3:2013 [9] and for the 1 950 mm pantograph in EBO [6]. The dimensions shown in red result from the real geometry of the pantograph head [15].

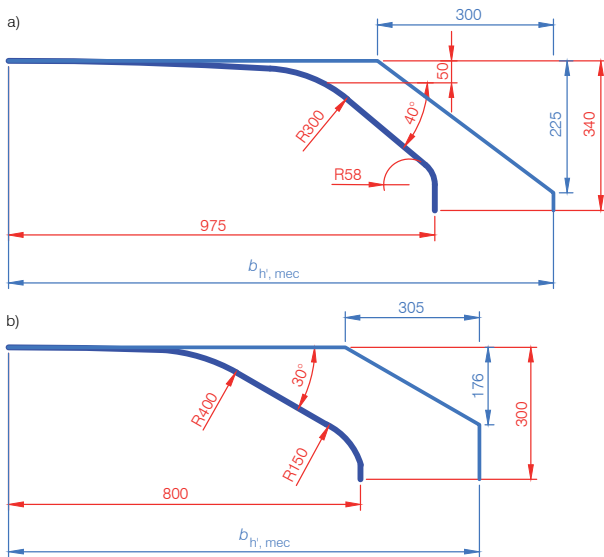

Fig. 8. Bevelling of pantograph gauges; dimensions in mm: a) 1 950 mm pantograph head b) 1 600 mm pantograph head

3. Useable contact wire lateral position

3.1. General

In order to minimize the wear of contact strips the contact wire is installed with a changing lateral position relative to the track axis. Under operational conditions the contact wire moves horizontally on the contact strips of the pantograph. In Germany, there is no stipulation for the minimum lateral movement of the pantograph related to the movement of the vehicle. Under the given conditions and the mechanical tolerances, the horizontal displacement of the contact wire and the pantograph may never lead to a derail-

ment of the pantograph head. The contact wire may also not leave the working length of the pantograph under the action of wind. If the working length of the pantograph is reduced by the horizontal total movement of the pantograph as the sum of E' and G' the useable contact wire lateral position results (Figures 2 and 9), which is also called maximum horizontal displacement of the contact wire in [22].

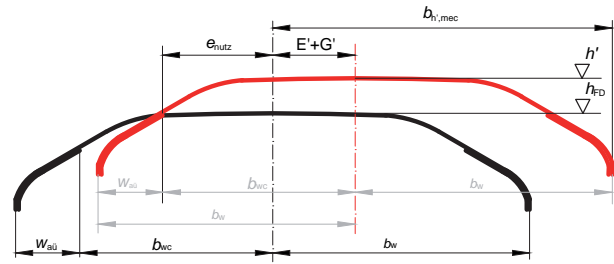

Fig. 9. Relation between the pantograph gauge and the useable contact wire lateral position

In Europe, there are differing rules to determine the useable contact wire lateral position. The TSI ENE [22] stipulates now a standardized, harmonized calculation procedure.

3.2. Calculation procedure

3.2.1. Useable contact wire lateral position

The useable contact wire lateral position depends on the horizontal movement of the pantograph head related to the track axis and, therefore, is directly related to the pantograph gauge which already considers the displacements of the pantograph.

The useable contact wire lateral position is, therefore, calculated by considering the horizontal total displacement of the pantograph and its working length according to [22]:

$$e_{nutz} = b_{w,c} + b_w - b'_{h',mec} \quad (26)$$

where

- $b_{w,c}$ – half working length of the pantograph head,
- b_w – half length of the pantograph head,
- $b'_{h',mec}$ – half width of the mechanical-kinematic pantograph gauge.

The TSI ENE [22] contains a faulty mathematical operator. The minus sign in equation (26) has been printed incorrectly as a positive sign in TSI ENE [22], section D.1.4. This mistake was corrected in [1]. Additionally, the Figure D.1 in TSI ENE [22] (see Figure 10) is incorrect as well: when presenting the derivation of the pantograph central axis Y'' the additional projection S' needs to be added to $qs' + \Sigma j$. This mistake has not yet been corrected.

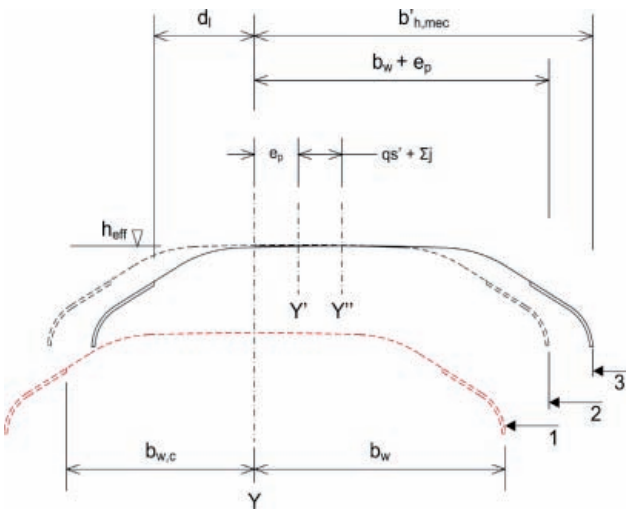

Caption:
 Y: Centre line of the track,
 Y': Centre line of the pantograph – for deriving the free passage reference profile,
 Y'': Centre line of the pantograph – for deriving the mechanical kinematic pantograph gauge,
 1: Pantograph profile,
 2: Free passage reference profile,
 3: Mechanical kinematic gauge.

Fig. 10. Pantograph mechanical gauges according to TSI ENE Figure D.1 [22];

The useable contact wire lateral position depends, therefore, on the radius, the cant and the cant deficiency and the working height of the pantograph as shown by the calculation of the mechanical-kinematic pantograph gauge. When determining the working height, the uplift at mid-span needs to be considered when calculating the useable contact wire lateral position. Additionally, the useable contact wire lateral position is limited to 400 mm in case of the 1 600 mm long pantograph and to 550 mm in case of the 1 950 mm long pantograph [22].

3.2.2. Working length of the pantograph head

For the determination of the working length of interoperable pantographs the stipulations of the TSI Rolling Stock [23] are decisive. There, reference is made to EN 50367:2012 [15], where the working lengths for the 1 600 mm long head is defined with 1 200 mm in Figure A.6 (see Figure 11a) and for the 1 950 mm long pantograph head with 1 550 mm in Figure A.7 (see Figure 11b). The working length of the pantographs consists of electrically conducting material.

The DB Net Directive 997.0101 [5] stipulates the working length of the 1 950 mm pantograph head as 1 450 mm. The contact range defined as the conducting range of the head within which the contact wire may move under consideration of all effects is defined by Ril 997.0101 [5] as half of the pantograph length reduced by 150 mm for the head projection. The contact range, therefore, results as 1 650 mm.

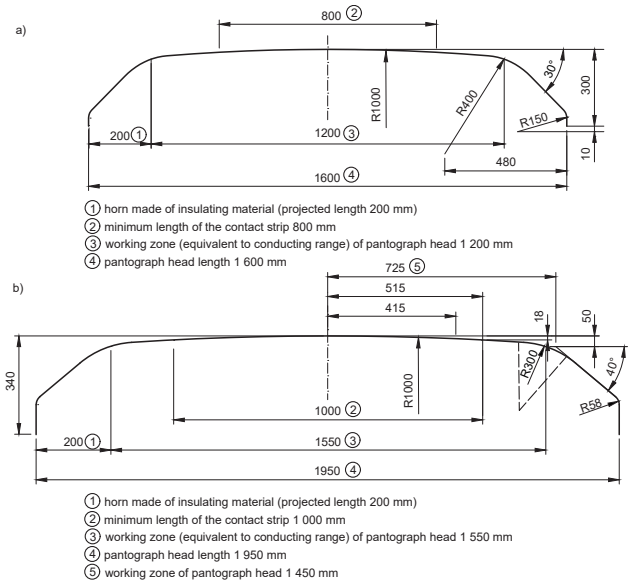

Fig. 11. Profiles for interoperable pantograph head according to EN 50367. a) Figure A.6, b) Figure A7 [14]

When the working length of the pantograph head is conducting, the working length and the contact range are identical. For the 1 950 mm long pantograph head, half of the working length according to [15] is, therefore, 775 mm which corresponds to 200 mm pantograph projection. The calculation needs to be based on this value because then the pantograph projection is identical with that of the 1 600 mm pantograph head. If otherwise, the 1450 mm working range is adopted according to 997.0101 [5] the useable contact wire lateral position is unnecessarily reduced by 50 mm, which would result in 5 m shorter longitudinal spans.

3.3. Impact of the reference cant

When calculating the reference gauge standard EN 15273-1 [11] distinguishes between the responsibilities on the vehicle side and on the infrastructure side. The portion E of the displacements is considered when establishing the vehicle gauge and the portion G in case of the infrastructure gauge (Figure 2). The interface between the two responsibilities is given by the reference gauge B.

Displacements which occur due to the inclination of the vehicle resulting from the quasi-static effects are part of the rolling stock manager's responsibility and also need to be considered partly by the infrastructure manager. The reference cant and the reference cant deficiency form thereby the interface between these responsibilities. The rolling stock manager considers all displacements due to quasi-static effects up to the reference cant and to the reference cant deficiency while the infrastructure manager takes responsibility only for cants and cant deficiencies above the refer-

ence cant and the reference cant deficiency as *additional* quasi-static displacements.

According to commitments agreed upon, the rolling stock manager is responsible for verifying analytically that no part of the vehicle exceeds the reference gauge. Thereby, the kinematic reference gauge considers in addition to the displacements from quasi-static inclination, also the transverse plays as well as installation tolerances (see section 2.2.4). As a basis for the calculation of the kinematic reference gauge the data for a reference vehicle according to EN 15273-3, Table F.2 [13] apply.

When designing a new vehicle the manufacturer of the vehicle may choose which parameters, for example, for the transverse play or the flexibility may be adopted, as long as the sum of vehicle body width and displacements do not exceed the reference gauge. For example the vehicle manufacturer may develop a relatively weakly suspended vehicle with high flexibility and on the other hand accept a reduction of the vehicle body or reverse, the manufacturer of the vehicle intends to design an especially wide vehicle body whereas the lateral displacements are reduced by an especially hard suspension [27].

The freedom with development of rolling stock is only possible by applying the kinematic calculation methodology. In case of the static calculation method used so far the infrastructure manager had to take into account all the dynamic effects when calculating the infrastructure gauge. The feature of the suspension did not have any effect on the rolling stock gauge and each vehicle, therefore, had approximately the same vehicle body width. An example for the optimum use of the kinematic reference gauge is formed by the development of the coaches of the first ICE generation [18].

For the reference cant and the reference cant deficiency over all values of 0,050 m for the calculation of the infrastructure gauge and the value 0,066 m for the calculation of the pantograph gauge were stipulated.

The value 0,050 m for the infrastructure gauge comes from its historical use in the Gotthard-Base-Tunnel, since a higher value would have led to a wider reference gauge and, therefore, a wider infrastructure gauge which would have required a greater distance between the adjacent tracks [17]. In order not to limit use of the Gotthard-Base-Tunnel as an important international transit route and to avoid expensive reconstruction, assumed value 0,050 m was excepted. For calculation of the additional quasi-static displacement and the pantograph gauge the TSI ENE [22] uses a lump reference cant and a reference deficiency of 0,066 mm. Probably, this data was caused by a lower flexibility of vehicles with pantographs compared with vehicles without pantographs. A more detailed reason of this value could not be found neither within the standards nor the technical literature.

This stipulation resulted in the fact that the mechanical-kinematic pantograph gauge always considers a quasi-static displacement of the vehicle bodies resulting from cants and cant deficiencies equal to the agreed overall values also in the case that the vehicle runs on a straight track without cant, where a cant deficiency cannot occur.

In case of a mechanical-kinematic pantograph gauge the real overall movement of the pantograph is not considered but always a vehicle inclined at least by the reference cant. Therefore, the consequence is that the calculation of the useable contact wire lateral position is not based on the real lateral movement of the pantograph but on the theoretical displacement taking into account the agreed overall values of the reference cant and the reference cant deficiency. These data were basically chosen for the definition of the structure gauge and the vehicle gauge.

In case of line sections with cants and / or cant deficiencies less than the reference cant or the reference cant deficiency the useable contact wire lateral position is unnecessarily limited.

In order to consider the real displacements of the pantograph for the calculation of the usable contact wire lateral position, the reference cant and the reference cant deficiency should not be considered and both values should be defined by 0,0 m in this case. This stipulation leads to the fact that the pantograph sway according to equations (11) and (12) will be reduced by the displacements of the quasi-static inclination to be taken into account for the vehicle and will be 0,065 m at the lower verification height as well as to 0,110 m at the upper verification height.

In the former calculation methodology to determine the useable contact wire lateral position according to TSI ENE HS [2] with reference to EN 50367:2006 [14] or UIC 606-1 [28] the reference cant and the reference cant deficiency were not considered.

3.4. Useable contact wire lateral position with or without reference cant

For the case $I'_0 = D'_0 = 0,066$ m according to [22] the useable contact wire lateral position results from

$$e_{use} = b_{w,c} - \frac{2,5}{R} - e \frac{l-1,435}{2} - 1,5 (D - 0,066)_{>0} (h - 0,5) + \left\{ (0,11 + \sum j_u) + \frac{h-5,0}{1,5} [(0,17 + \sum j_0) - (0,11 + \sum j_u)] \right\}. \quad (27)$$

For the case $I'_0 = D'_0 = 0,0$ m the useable contact wire lateral position results to be

$$e_{use} = b_{w,c} - \frac{2,5}{R} - \frac{l-1,435}{2} - 1,5Dh + 0,075D + \left\{ (0,065 + \sum j_u) + \frac{h-5,0}{1,5} [(0,11 + \sum j_0) - (0,065 + \sum j_u)] \right\}. \quad (28)$$

In Table 5 a numeric example for a straight track without cant with randomly caused displacements according to EBO as well as with the parameters according to Table 1 with and without consideration of the reference cant is carried out. It can be seen that the difference in results of both calculations sums up to 60 mm. Therefore, in a straight track, for example, spans shorter by 8 m result for the overhead contact line type Re200. Additionally, it can be seen that the limiting value of 400 mm for the 1 600 mm long pantograph even in the most unfavourable case that is straight line without cant will not be reached in case of consideration of the reference cant. The same applies for the 1 950 mm long pantograph which equates to 525 mm useable contact wire lateral position when taking into account the reference cant at 5,86 mm verification height but not to 550 mm as accepted so far.

4. Effects on overhead contact line systems

Commencing on 1 January 2015 the TSI ENE [22] forms the basis for planning of overhead contact lines on all types of lines of the trans-European railway system. By harmonizing the calculation rules for conventional railway system and the high-speed railway system the TSI ENE represents an important step towards further harmonizing the European railway system. The calculation of the mechanical-kinematic pantograph gauge and the useable contact wire lateral position, from this date needs to be done according to the calculation rules stipulated in TSI ENE [22] and in EN 15273-1 [11].

Also from this date onwards a system design using the stepped curve according to Ebs 02.05.49 [8] is no

longer considered accepted state of the art. According to TSI ENE [22] the useable contact wire lateral position does not only depend on the curve radius but also on the contact wire height, the cant and the cant deficiency. These effects have not been considered so far in the regulation of DB. Within the DB Network Directive 997.0101 [5] it is, therefore, stated that the stipulations of the directive 96/48/EG for the interoperability of the trans-European high-speed railway system are not considered by the above mentioned DB directive.

The pantograph gauge and the useable contact wire lateral position depend on parameters, which so far have not yet been harmonized within Europe. This applies especially to the permitted tolerances and limits for the track position established by the individual infrastructure managers.

For system design there should be a distinction between the calculation of the mechanical-kinematic pantograph gauge and the useable contact wire lateral position. On this basis the simplified formulae (25) and (27), respectively, can be applied analogously to the L_2 equation in EN 50367:2006 [14] or TM 2011-154 [24] and may be used as a planning basis for overhead contact lines [21].

5. Suggestions for supplementing the TSI Energy

5.1. Reference parameters

For future issues with the TSI ENE the reference parameters for the determination of the useable contact wire lateral position should be adjusted to the track geometry, that is, as explained in clause 3.3, that the reference cant within straight lines should be assumed as 0,0 and the sway of the pantograph should be reduced accordingly.

In addition, as explained in clause 2.2.3 the geometric sum should also be used for the determination of pantograph sway at the upper verification point. The useable contact wire lateral position, therefore,

Table 5

Useable contact wire lateral position with and without reference cant; all dimensions in m

Verification height h	Pantograph type 1600 mm			Pantograph type 1950 mm		
	$D'_0 = I'_0 = 0,066$	$D'_0 = I'_0 = 0,000$	Difference	$D'_0 = I'_0 = 0,066$	$D'_0 = I'_0 = 0,000$	Difference
5,00	0,396	0,441	0,045	0,571	0,616	0,045
5,52	0,368	0,418	0,050	0,543	0,593	0,050
5,86	0,350	0,404	0,054	0,525	0,579	0,054
6,50	0,316	0,376	0,060	0,491	0,551	0,060

Parameter according to Table 1, randomly related displacements according to Table 3 (not fixed track), without constraints.

would be up to 30 mm wider and, for example, would permit three Meter longer spans in case of the overhead contact line type Re200, without limiting the reliability of the interaction of pantograph and overhead contact line.

5.2. Limitation of the useable contact wire lateral position

The calculation of the useable contact wire lateral position refers to a specified contact wire height. The lower the verification height, the wider the permissible useable contact wire lateral position. In TSI ENE [22] the useable contact wire lateral position, however, is limited to 0,400 m for operation with the 1 600 mm long pantograph and to 0,550 m for operation with the 1 950 mm long pantograph regardless of the contact wire height, which is not a reasonable procedure. In case of lower contact wire heights, higher values for the useable contact wire lateral position are possible as revealed in Table 5. Without this limitation longer spans would be possible resulting in lower capital costs and reduced maintenance expenditure.

5.3. Randomly-caused displacements

In Europe individual infrastructure managers may establish the tolerances for track quality to determine the randomly caused displacements according to EN 15273-3:2013 [13].

Thereof, according to the calculation methodology established by the TSI ENE for the pantograph gauge, therefore for the useable contact wire lateral position differing results are obtained [19]. This contradicts to the concept of harmonization within the European railway system. Therefore, the tolerances for the track quality should be established uniformly for Europe or the randomly-related displacements for the calculation of the pantograph gauge should be stipulated which cover the most unfavourable applications.

Literature

1. Corrigendum to the Regulation No. 1301/2014/EU: Technical specification for the interoperability of the energy subsystem of the railway system in the European Union, In: Official Journal of the European Union, No. L 13 (2015), p. 13.
2. Decision 2008/284/EU: Technical specification for the interoperability of the energy subsystem of the trans-European high-speed railway system, In: Official Journal of the European Union, No. L104 (2008), pp. 1 to 79.
3. Decision 2011/274/EC: Technical specification for the interoperability of the energy subsystem of the conventional trans-European high-speed railway system, In: Official Journal of the European Union. No. L 126 (2011), pp. 1 to 52.
4. Die Regelfahrleitung der Deutschen Bundesbahn (The standard contact lines of German Railway), In: Elektrische Bahnen 77 (1979) Vol. 6, pp. 175 – to 180 and pp. 207 to 208.
5. Directive Ril 821:200: Oberbau inspizieren (Inspection of permanent way), DB Net AG, Frankfurt, 2010.
6. Directive Ril 997.0101: Oberleitungsanlagen; Allgemeine Grundsätze (Overhead contact line systems; General aspects), DB Net AG, 2001.
7. EBO: Eisenbahn-Bau und Betriebsordnung (Ordinance on the Construction and Operation of Railways). Bundesrepublik Deutschland, BGBl, 1967 II S. 1/,563, mit letzter Änderung durch Artikel 1 der Verordnung vom 25. Juli 2012 (BGBl. I S. 1703).
8. Ebs 02.05.45 Part. 1: Seitenhalter-Stellung (Abnahme) (Position of steady arms (Acceptance). DB Netz AG, Frankfurt, 2008.
9. Ebs 02.05.49 Part.1: Längsspannweite und Seitenverschiebung des Fahrdrabtes – Deckblatt (Longitudinal span and displacement of contact wire (Cover page)). DB Net AG, Frankfurt, 2000.
10. Eisenbahn-Bundesamt: Neue TSI veröffentlicht – Inkrafttreten 01.01.2015, In: Fachmitteilung, Nr. 30/2014, Bonn.
11. Eisenbahn-CERT: Technical File for Catenary Re200, Re200i and Re200 without steady arm, 2011, Bonn.
12. EN 15273-1:2013: Railway applications – Gauges – Part 1: General – Common rules for infrastructure and rolling stock.
13. EN 15273-2:2013: Railway applications – Gauges – Part 2: Rolling stock gauge.
14. EN 15273-3:2013: Railway applications – Gauges – Part 3: Structure gauges.
15. EN 50367:2006: Railway applications – Current collection systems – Technical criteria for the interaction between pantograph and overhead line to achieve free access.
16. EN 50367:2012: Railway applications – Current collection systems – Technical criteria for the interaction between pantograph and overhead line to achieve free access.
17. Hormig U., Krötz W.: *Zusammengeführte Technische Spezifikation Energie für das interoperable Bahnsystem* (Combined technical specification energy for the interoperable railway system). In: Elektrische Bahnen 112 (2014), Vol. 11–12, pp. 661 to 667.
18. Jacobs K., Mittmann W.: *Neue Lichtraumbestimmungen auf kinematischer Grundlage – Regeln, Auswirkungen, Perspektiven* (New determination

- of gauges on a kinematic basis – Rules, effects, perspectives), In: Heinisch R., Koch P., Kracke R., Rahn T. (Editors): Edition ETR: Construction and maintenance of railway systems, pp. 241 to 249, Hestra-Publishing, Darmstadt, 1993.
19. Jänsch E.: *Die Abmessungen der Mittelwagen des Intercity Express* (The dimensions of the coaches of the Intercity Express). In: ETR 37 (1988), Vol. 4, pp. 197 to 204.
 20. Kießling F., Puschmann R., Schmieder A.: *Overhead contact lines for electric railways. Publicis publishers*, Erlangen, 2nd Edition, 2009.
 21. Nickel T.: *Untersuchung zu Auswirkungen der verminderten Fahrdrabt-Seitenlage auf das Ebs-Zeichnungswerk* (Investigation on the effects of a reduced contact wire lateral position on the standard drawings of DB), TU Dresden, diploma thesis, 2011.
 22. Regulation 1301/2014/EU: Technical specification for the interoperability of the energy subsystem of the rail system in the Union. In: Official Journal of the European Union, No. L 356 (2014), pp. 179 to 227.
 23. Regulation 1302/2014/EU: Technical specification for the interoperability of the locomotive and passenger wagon of the railway system in the European Union, In: Official Journal of the European Union, No. L 356 (2014), pp. 228 to 393.
 24. Technical information TM 2011-154: on Ril 997 – Oberleitungsanlagen – Bauarten Re 100, Re 200, Re 200mod – Berücksichtigung der interoperablen Stromabnehmerwippe nach DIN EN 50367:2006, Bild A.7 (Concerning Ril 997 – Overhead contact lines – Types Re 100, Re 200, Re 200mod – Consideration of the interoperable pantograph head according to EN 50367:2006, Figure A.7). DB Net AG, Frankfurt, 2011.
 25. UIC-codex 505-1: 2006: Railway transport stock – Rolling stock construction gauge. UIC, Paris.
 26. UIC-codex 505-4: 2008: Effects of the application of the kinematic gauges defined in the 505 series of leaflets on the positioning of structures in relation to the tracks and of the tracks in relation to each other, UIC, Paris.
 27. UIC-codex 505-5:2010: History, justification and commentaries on the elaboration and development of UIC leaflets of the series 505 and 506 on gauges. UIC, Paris.
 28. UIC-codex 606-1:1987: Consequences of the application of the kinematic gauge defined by UIC Leaflets in the 505 series on the design of the contact lines. UIC, Paris.

Techniczna specyfikacja Energia 2015 – zharmonizowany projekt sieci trakcyjnych

Streszczenie

W grudniu 2014 roku opublikowano Techniczne specyfikacje interoperacyjności podsystemu „Energia” systemu kolei w Unii. Specyfikacja weszła w życie od 1 stycznia 2015 roku i zastąpiła dotychczasowe specyfikacje dotyczące kolei konwencjonalnych i kolei dużych prędkości. Dokument określa szczegółowe zasady projektowania mechanicznej skrajni kinematycznej pantografu i maksymalne odchylenie poprzeczne przewodu jezdnego. Zharmonizowane postanowienia skutkują planowaniem danych dla przewodów trakcyjnych, które różnią się od wcześniej projektowanych uzyskiwanych wartości. Ponadto, artykuł określa niezbędne suplementy do kolejnej technicznej specyfikacji dla zapewnienia interoperacyjności systemu energetycznego.

Słowa kluczowe: sieć trakcyjna, interoperacyjność, techniczna specyfikacja dla zapewnienia interoperacyjności w podsystemie energetycznym, koleje konwencjonalne, koleje dużych prędkości, mechaniczna skrajnia kinematyczna pantografu, elektryczna skrajnia kinetyczna pantografu, suplement do technicznej specyfikacji dla zapewnienia interoperacyjności w podsystemie energetycznym

Техническая спецификация TSI Energy 2015 – согласованный проект контактных линий

Резюме

В декабре 2014 г. была опубликована техническая спецификация для интероперабельности в области энергоэлектрической подсистемы в Европейском союзе. Эта спецификация вступает в силу с 1 января 2015 г. и заменяет прежние индивидуальные технические спецификации для интероперабельности для систем традиционной и высокоскоростной железных дорог. Документ подробно определяет правила проектирования механической кинематической контурной линии пантографа и максимального бокового отклонения контактного провода. Согласованные установки приводят к планировке данных для контактного провода которые отличаются от значений проектированных раньше. Кроме того в статье определяются необходимые приложения к технической спецификации для интероперабельности в области энергоэлектрической подсистемы.

Ключевые слова: контактная сеть, интероперабельность, техническая спецификация для интероперабельности, энергоэлектрическая подсистема, традиционная железная дорога, высокоскоростная железная дорога, механическая кинематическая контурная линия пантографа, электрическая кинематическая контурная линия пантографа, приложения к технической спецификации для интероперабельности в области энергоэлектрической подсистемы